



FORGED STEEL FLANGES

PO BOX 639
Bakersfield, CA 93302

855-535-1555 phone
sales@tbmsupply.com

Nom. Pipe Size	Pipe O.D. (in.)	Wall Thickness													F													
		Light Wall	SCH 20	SCH 30	STD	SCH 40	SCH 60	X STG	SCH 80	SCH 100	SCH 120	SCH 140	SCH 160	XX STG	A	B	D	E	ANSI	MSS	G	O	K	S	V	X	Y	
1/2	.84				.109	.109		.147	.147					.188	.294	1.50	.62		1.00	3.00	2.00	1.38	3.00	1.88				
3/4	1.05				.113	.113		.154	.154					.219	.308	1.12	.44		1.00	3.00	2.00	1.69	2.25	1.69				
1	1.32				.133	.133		.179	.179					.250	.358	1.50	.88	1.00	1.50	4.00	2.00	2.00	3.00	2.19	2.00	1.62		
1 1/4	1.66				.140	.140		.191	.191					.250	.382	1.88	1.00	1.25	1.50	4.00	2.00	2.50	3.75	2.75	2.50	2.06		
1 1/2	1.90				.145	.145		.200	.200					.281	.400	2.25	1.12	1.50	1.50	4.00	2.00	2.88	4.50	3.25	3.00	2.44		
2	2.38				.154	.154		.218	.218					.344	.436	3.00	1.38	2.00	1.50	6.00	2.50	3.62	6.00	4.19	4.00	3.19	6.00	2.50
2 1/2	2.88				.203	.203		.276	.276					.375	.552	3.75	1.75	2.50	1.50	6.00	2.50	4.12	7.50	5.19	5.00	3.94		
3	3.50	.188			.216	.216		.300	.300					.438	.600	4.50	2.00	3.00	2.00	6.00	2.50	5.00	9.00	6.25	6.00	4.75	9.00	3.75
3 1/2	4.00				.226	.226		.318	.318							5.25	2.25	3.50	2.50	6.00	3.00	5.50	10.50	7.25	7.00	5.50		
4	4.50	.188			.237	.237		.337	.337			.438		.531	.674	6.00	2.50	4.00	2.50	6.00	3.00	6.19	12.00	8.25	8.00	6.25	12.00	5.00
5	5.56				.258	.258		.375	.375			.500		.625	.750	7.50	3.12	5.00	3.00	8.00	3.00	7.31	15.00	10.31	10.00	7.75		
6	6.62	.219			.280	.280		.432	.432			.562		.719	.864	9.00	3.75	6.00	3.50	8.00	3.50	8.50	18.00	12.31	12.00	9.31	18.00	7.50
8	8.62	.219	.250	.277	.322	.322	.406	.500	.500	.594	.719	.812	.906	.875	12.00	5.00	8.00	4.00	8.00	4.00	10.62	24.00	16.31	16.00	12.31	24.00	10.00	
10	10.2	.219	.250	.307	.365	.365	.500	.500	.594	.719	.844	1.000	1.125	1.000	15.00	6.25	10.00	5.00	10.00	5.00	12.75	30.00	20.38	20.00	15.38	30.00	12.50	
12	12.75	.250	.250	.330	.375	.406	.562	.500	.688	.844	1.000	1.125	1.312	1.000	18.00	7.50	12.00	6.00	10.00	6.00	15.00	36.00	24.38	24.00	18.38	36.00	15.00	
14	14.00	.250	.312	.375	.375	.438	.594	.500	.750	.938	1.094	1.250	1.406		21.00	8.75	14.00	6.50	12.00	6.00	16.25	42.00	28.00	28.00	21.00	42.00	17.50	
16	16.00	.250	.312	.375	.375	.500	.656	.500	.844	1.031	1.219	1.438	1.594		24.00	10.00	16.00	7.00	12.00	6.00	18.50	48.00	32.00	32.00	24.00	48.00	19.88	
18	18.00	.250	.312	.438	.375	.562	.750	.500	.938	1.156	1.375	1.562	1.781		27.00	11.25	18.00	8.00	12.00	6.00	21.00	54.00	36.00	36.00	27.00	54.00	22.38	
20	20.00	.250	.375	.500	.375	.594	.812	.500	1.031	1.281	1.500	1.750	1.969		30.00	12.50	20.00	9.00	12.00	6.00	23.00	60.00	40.00	40.00	30.00	60.00	24.88	
24	24.00	.250	.375	.562	.375	.688	.969	.500	1.219	1.531	1.812	2.062	2.344		36.00	15.00	24.00	10.50	12.00	6.00	27.25	72.00	48.00	48.00	36.00	72.00	29.81	
30	30.00	.312	.500	.625	.375			.500							45.00	18.50	30.00	10.50				90.00	60.00	60.00	45.00	90.00	37.25	
36	36.00	.312	.500	.625	.375	.750		.500							54.00	22.25	36.00	10.50						72.00	54.00	108.00	44.75	
42	42.00				.375			.500							63.00	26.00	42.00	12.00								126.00	52.19	
48	48.00				.375			.500							72.00	29.88	48.00	13.50									144.00	59.69

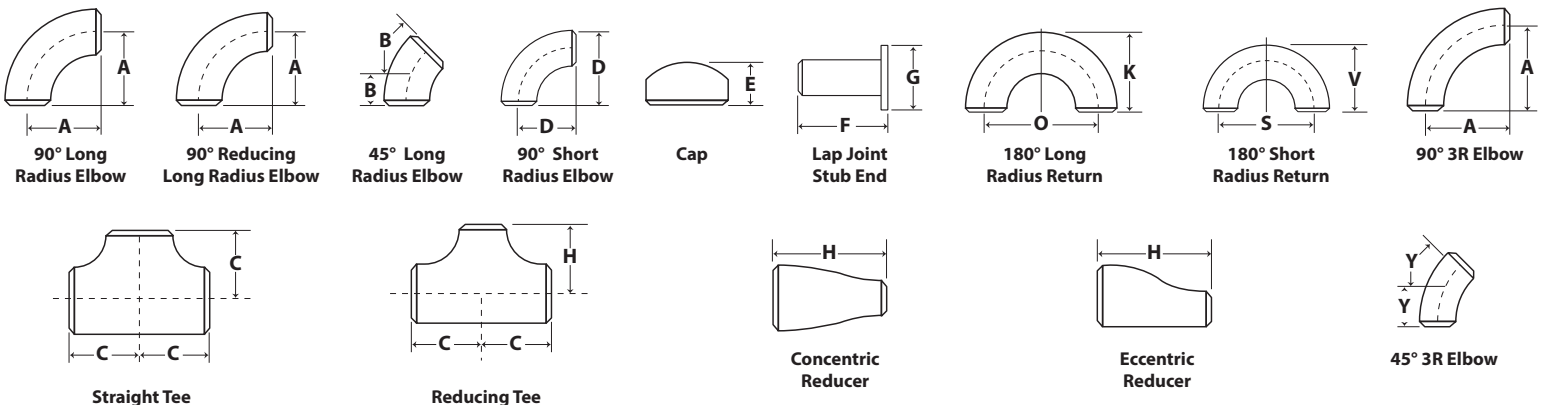

NOTES: Fittings conform to ASTM A234 WPB with dimensions to ANSI B16.9 except that short radius elbows and returns conform to ANSI B16.28 and 3R elbows conform to MSS-SP75.

BPS, Inc. is not responsible for any printing errors in the data contained herein. Although care was taken for proper representation, verification of all specifications is the sole responsibility of the customer.



FORGED STEEL FLANGES

PO BOX 639
Bakersfield, CA 93302

855-535-1555 phone
sales@tbmsupply.com

Nom. Pipe Size		Nom. Pipe Size			Nom. Pipe Size					Nom. Pipe Size										
Run	Outlet	C	M	H	Run	Outlet	C	M	H	Run	Outlet	C	M	H	Run	Outlet	C	M	H	
3/4	3/4	1.12		1.50	3 1/2	3 1/2	3.75			12	12	10.00			24	24	17.00			
	1/2	1.12	1.12			3	3.75	3.62	4.00		10	10.00	9.50	8.00				22	17.00	17.00
1	1	1.50		2.00	4	2 1/2	3.75	3.50	4.00	14	8	10.00	9.00	8.00	30	20	17.00	17.00	20.00	
	3/4	1.50	1.50			2	3.75	3.25	4.00		6	10.00	8.62	8.00			18	17.00	16.50	20.00
	1/2	1.50	1.50			1 1/2	3.75	3.12	4.00		5	10.00	8.50	8.00			16	17.00	16.00	20.00
		1 1/4	1.88				4	4.12				14	11.00	11.00				14	17.00	16.00
1 1/4	1	1.88	1.88	2.00	5	3 1/2	4.12	4.00	4.00	16	12	11.00	10.62	13.00	36	12	17.00	15.62		
	3/4	1.88	1.88			3	4.12	3.88	4.00		14	11.00	10.12	13.00			10	17.00	15.12	
	1/2	1.88	1.88			2 1/2	4.12	3.75	4.00		8	11.00	9.75	13.00			30	22.00		
		1 1/2	2.25			2	4.12	3.50	4.00		6	11.00	9.38	13.00			24	22.00	21.00	24.00
1 1/2	1 1/4	2.25	2.25	2.50	6	1 1/2	4.12	3.38	4.00	18	16	12.00			42	20	22.00	20.00	24.00	
	1	2.25	2.25			5	4.88				14	12.00	12.00	14.00			18	22.00	19.50	
	3/4	2.25	2.25			4	4.88	4.62	5.00		12	12.00	11.62	14.00			16	22.00	19.00	
	1/2	2.25	2.25			3 1/2	4.88	4.50	5.00		10	12.00	11.12	14.00			14	22.00	19.00	
2	2	2.50		3.00	8	3	4.88	4.38	5.00	20	8	12.00	10.75	14.00	48	36	26.50			
	1 1/2	2.50	2.38	3.00		2 1/2	4.88	4.25	5.00		6	12.00	10.38				30	26.50	25.00	24.00
	1 1/4	2.50	2.25	3.00		2	4.88	4.12	5.00		18	13.50					24	26.50	24.00	24.00
	1	2.50	2.00	3.00		6	5.62				16	13.50	13.00	15.00			20	26.50	23.00	
2 1/2	3/4	2.50	2.25	3.00	10	5	5.62	5.38	5.50	18	14	13.50	13.00	15.00	36	18	26.50	22.50		
	1/2	2.50	2.25			4	5.62	5.12	5.50		12	13.50	12.62	15.00			16	26.50	22.00	
		2 1/2	3.00			3 1/2	5.62	5.00	5.50		10	13.50	12.12	15.00			42	30.00		
		2	3.00	2.75		3.50	3	5.62	4.88		5.50	8	13.50	11.75				36	30.00	28.00
3	1 1/4	3.00	2.50	3.50	12	2 1/2	5.62	4.75	5.50	20	20	15.00			42	30	30.00	28.00	24.00	
	1	3.00	2.25	3.50		8	7.00				18	15.00	14.50	20.00			24	30.00	26.00	
		3	3.38			6	7.00	6.62	6.00		16	15.00	14.00	20.00			20	30.00	26.00	
		2 1/2	3.38	3.25		3.50	5	7.00	6.38		6.00	14	15.00	14.00		20.00		48	35.00	
3	2	3.38	3.00	3.50	14	4	7.00	6.12	6.00	20	12	15.00	13.62	20.00	48	42	35.00	32.00	28.00	
	1 1/2	3.38	2.88	3.50		3 1/2	7.00	6.00	6.00		10	15.00	13.12				36	35.00	31.00	
	1 1/4	3.38	2.75	3.50		10	8.50				8	15.00	12.75				30	35.00	30.00	
						8	8.50	8.00	7.00								24	35.00	29.00	
					10	8.50	7.62	7.00												
						5	8.50	7.50	7.00											
						4	8.50	7.25	7.00											

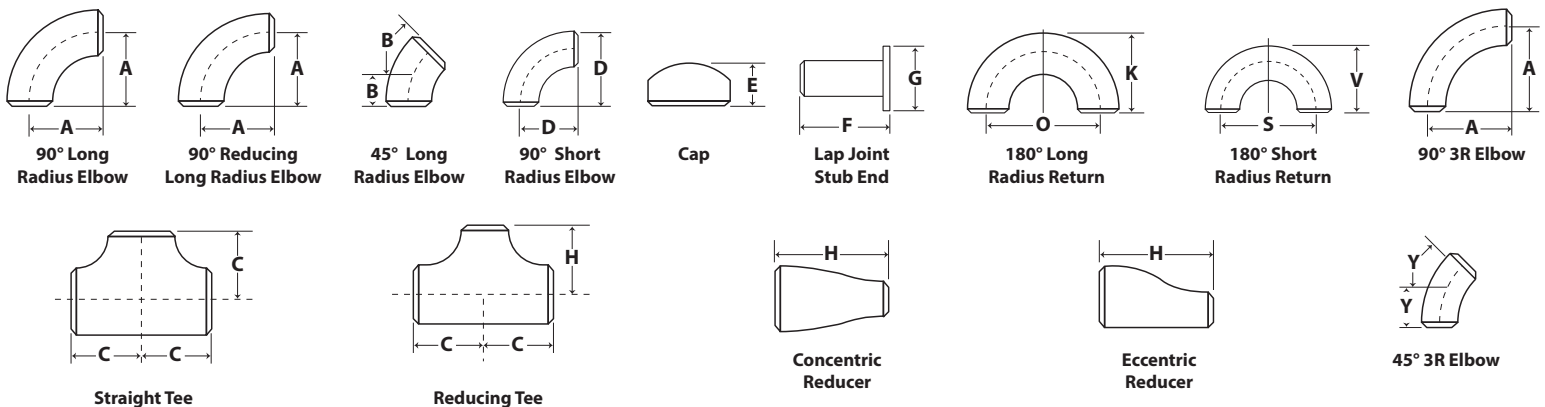

NOTES: Fittings conform to ASTM A234 WPB with dimensions to ANSI B16.9 except that short radius elbows and returns conform to ANSI B16.28 and 3R elbows conform to MSS-SP75.

BPS, Inc. is not responsible for any printing errors in the data contained herein. Although care was taken for proper representation, verification of all specifications is the sole responsibility of the customer.